



## Original Article

### 3 G based industrial automation using GSM communication

Ahmed M<sup>1\*</sup>, Farooqui H<sup>2</sup>, Farooqui S<sup>3</sup>, Ahmad S<sup>4</sup>, M.S.Harsoliya<sup>5</sup>, J.K.Pathan<sup>2</sup>

1. VIT, Indore
2. SVCP, Indore
3. MDC & RC, Indore
4. Columbia University, USA
5. JJT University, Rajasthan

Correspondence author: Masood Ahmed ([sharsoliya@yahoo.co.in](mailto:sharsoliya@yahoo.co.in), 9039056339)

Received 09 June 2011; accepted 22 June 2011

#### Abstract

The proposed project is based on the concept of Industrial automation. In this project, we are going to develop a project basically dependent on DTMF, Microcontroller & relay etc. The system allows complete security and is based on microcontroller. The design objective of this project is to make a DTMF based remote monitoring system which can be used to acquire different parameters of any process or machine and send the data obtained to a distant logging system running on a PC so that the data can be represented in a user friendly manner. Here microcontroller is the heart of this project, Firstly the power supply of 5v DC is very essential for this set up, this power supply trigger the microcontroller 8051, then 8051 is directly connected with LCD & device control, LCD gives the info regarding devices that can be operated by microcontroller 8051 & device control here acting as a switch with the help of relays. DTMF encoder sends the information in the form of frequency from the 3G hand set, Then DTMF decoder decode the information in the form of frequency and this information fed to microcontroller pins. Finally microcontroller performs the relative operations.

© 2011 Universal Research Publications. All rights reserved

**Keywords:** 3 G, Industrial automation, GSM communication

#### INTRODUCTION

Industrial automation is a field within automation, specializing in the specific automation requirements of industries and in the application of automation techniques for the comfort and security of its parts. Although many techniques used in industrial automation (such as plant and machines control, control of window shutters, security and surveillance systems, etc.) Automation are also used in home automation, additional functions in home automation include the control of multi-media home entertainment systems,

automatic plant watering and pet feeding, and automatic scenes for dinners and parties.

In this project the industrial automation, is controlled by a mobile phone that makes call to the mobile phone attached to the industrial automation in the course of the call, if any button is pressed control corresponding to the button pressed is heard at the other end of the call. This tone is called dual tone multi frequency tone (DTMF) industrial automation receives this DTMF tone with the help of phone stacked in the industrial automation The received tone is processed by the DTMF decoder LM8870 the decoder

The tones and assignments in a DTMF system shown below.

Frequencies	1209Hz	1336Hz	1477Hz	1633Hz
697Hz	1	2	3	A
770Hz	4	5	6	B
852Hz	7	8	9	C
941Hz	*	0	#	D

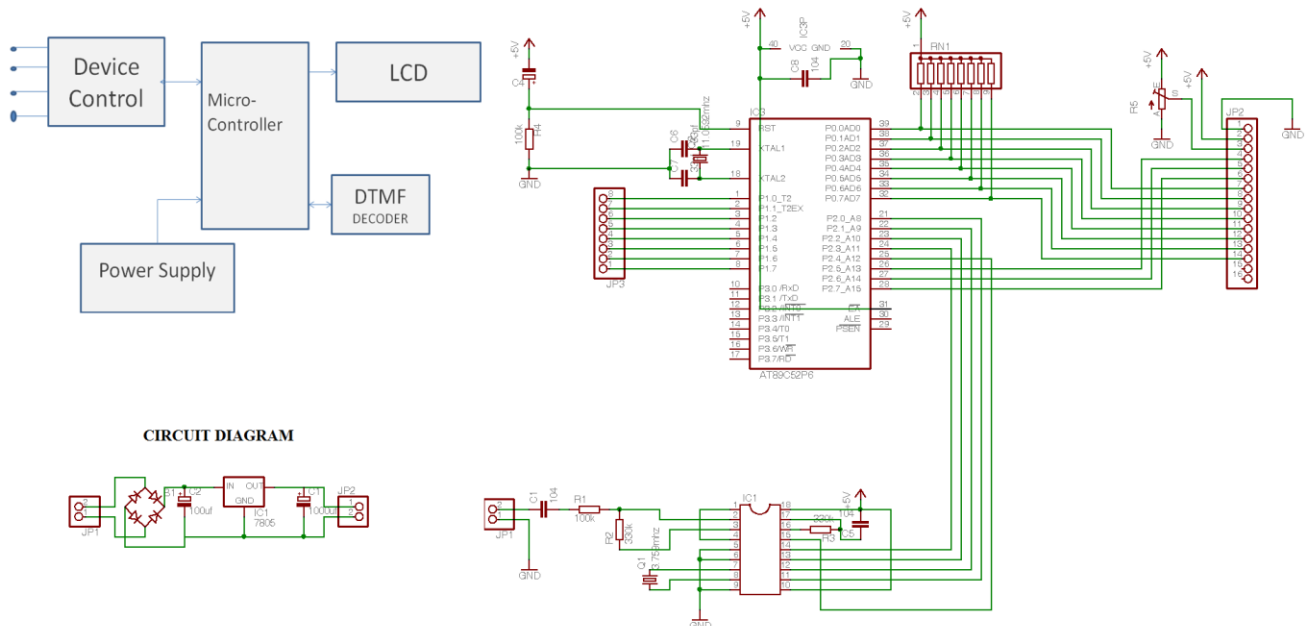

decodes the DTMF tone in to its equivalent binary digit and this binary number is send to the IC 89S51, the IC 89S51 to take a decision for any give input and outputs .DTMF signaling is used for telephone signaling over the line in the voice frequency band to the call switching center. The version of DTMF used for telephone dialing is known as touch tone. DTMF assigns a specific frequency (consisting of two separate tones) to each key s that it can easily be identified by the electronic circuit. The signal generated by the DTMF encoder is the direct al-gerbil submission, in real time of the amplitudes of two sine (cosine) waves of different frequencies, i.e., pressing 5 will send a tone made by adding 1336 Hz and 770 Hz to the other end of the mobile.

Although the original DTMF keypad had an additional column for four now-defunct menu selector keys. When used to dial a telephone number, pressing a single key will produce a pitch consisting of two simultaneous pure tone sinusoidal frequencies. The row in which the key appears determines the *low* frequency, and the column determines the *high* frequency. For example, pressing the '1' key will result in a sound composed of both a 697 and a 1209 hertz (Hz) tone. The original keypads had levers inside, so each button activated two contacts. The multiple tones are the reason for calling the system multi frequency. These tones are then

decoded by the switching center to determine which key was pressed.

**CIRCUIT DIAGRAM**

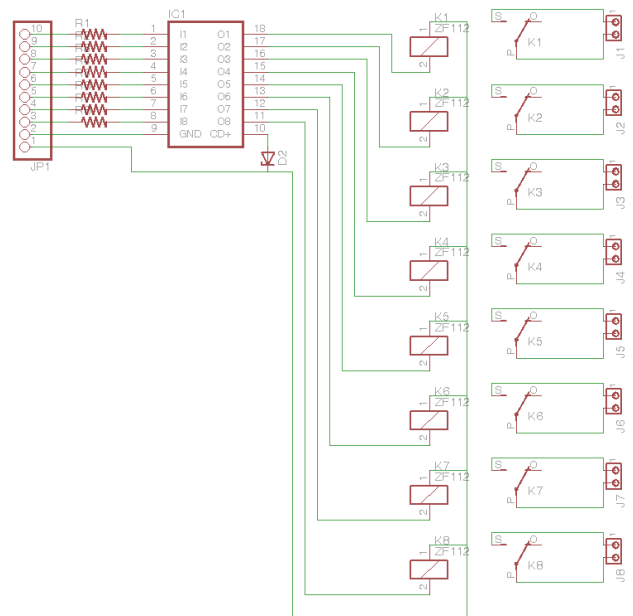

## MICRO CONTROLLER

### Features

- Compatible with MCS-51™ Products
- 4K Bytes of In-System Reprogrammable Flash Memory
  - Endurance: 1,000 Write/Erase Cycles
- Fully Static Operation: 0 Hz to 24 MHz
- Three-Level Program Memory Lock
- 128 x 8-Bit Internal RAM
- 32 Programmable I/O Lines
- Two 16-Bit Timer/Counters
- Six Interrupt Sources
- Programmable Serial Channel
- Low Power Idle and Power Down Modes

### Pin Configurations

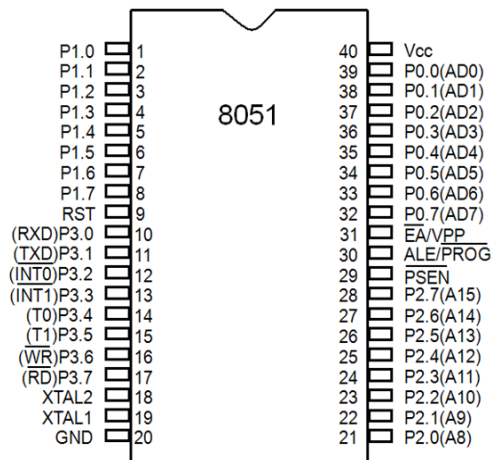

The AT89S51 provides the following standard features: 4K bytes of Flash, 128 bytes of RAM, 32 I/O lines, two 16-bit timer/counters, a five vector two-level interrupt architecture, a full duplex serial port, on-chip oscillator and clock circuitry. In addition, the AT89S51 is designed with static logic for operation down to zero frequency and supports two software selectable power saving modes. The Idle Mode stops the CPU while allowing the RAM, timer/counters, serial port and interrupt system to continue functioning. The Power Down Mode saves the RAM contents but freezes the oscillator disabling all other chip functions until the next hardware reset.

### Port 0

Port 0 is an 8-bit open drain bidirectional I/O port. As an output port each pin can sink eight TTL inputs. When 1s are written to port 0 pins, the pins can be used as high impedance inputs. Port 0 may also be configured to be the multiplexed low order address/data bus during accesses to external program and data memory. In this mode P0 has internal pullups. Port 0 also receives the code bytes during Flash programming, and outputs the code bytes during program verification. External pullups are required during program verification.

### Port 1

Port 1 is an 8-bit bidirectional I/O port with internal pullups. The Port 1 output buffers can sink/source four TTL inputs. When 1s are written to Port 1 pins they are pulled high by the internal pullups and can be used as inputs. As inputs, Port 1 pins that are externally being pulled low will source current (IIL) because of the internal pullups. Port 1 also receives the low-order address bytes during Flash programming and verification.

### Port 2

Port 2 is an 8-bit bidirectional I/O port with internal pullups. The Port 2 output buffers can sink/source four TTL inputs. When 1s are written to Port 2 pins they are pulled high by the internal pullups and can be used as inputs. As inputs, Port 2 pins that are externally being pulled low will source current (IIL) because of the internal pullups. Port 2 emits the high-order address byte during fetches from external program memory and during accesses to external data memory that use 16-bit addresses (MOVX @ DPTR). In this application it uses strong internal pullups when emitting 1s. During accesses to external data memory that use 8-bit addresses (MOVX @ RI), Port 2 emits the contents of the P2 Special Function Register. Port 2 also receives the high-order address bits and some control signals during Flash programming and verification.

### Port 3

Port 3 is an 8-bit bidirectional I/O port with internal pullups. The Port 3 output buffers can sink/source four TTL inputs. When 1s are written to Port 3 pins they are pulled high by the internal pullups and can be used as inputs. As inputs, Port 3 pins that are externally being pulled low will source current (IIL) because of the pullups. Port 3 also serves the functions of various special features of the AT89S51 as listed below:

#### Port Pin Alternate Functions

- P3.0 RXD (serial input port)
- P3.1 TXD (serial output port)
- P3.2 INT0 (external interrupt 0)
- P3.3 INT1 (external interrupt 1)
- P3.4 T0 (timer 0 external input)
- P3.5 T1 (timer 1 external input)
- P3.6 WR (external data memory write strobe)
- P3.7 RD (external data memory read strobe)

Port 3 also receives some control signals for Flash programming and verification.

#### RST

Reset input. A high on this pin for two machine cycles while the oscillator is running resets the device.

#### ALE/PROG

Address Latch Enable output pulse for latching the low byte of the address during accesses to external memory. This pin is also the program pulse input (PROG) during Flash

programming. In normal operation ALE is emitted at a constant rate of 1/6 the oscillator frequency, and may be used for external timing or clocking purposes. Note, however, that one ALE pulse is skipped during each access to external Data Memory. If desired, ALE operation can be disabled by setting bit 0 of SFR location 8EH. With the bit set, ALE is active only during a MOVX or MOVC instruction. Otherwise, the pin is weakly pulled high. Setting the ALE-disable bit has no effect if the microcontroller is in external execution mode.

**PSEN**

Program Store Enable is the read strobe to external program memory. When the AT89S51 is executing code from external program memory, PSEN is activated twice each machine cycle, except that two PSEN activations are skipped during each access to external data memory

**EA/VPP**

External Access Enable. EA must be strapped to GND in order to enable the device to fetch code from external program memory locations starting at 0000H up to FFFFH. Note, however, that if lock bit 1 is programmed, EA will be internally latched on reset. EA should be strapped to VCC for internal program executions. This pin also receives the 12-volt programming enable voltage (VPP) during Flash programming, for parts that require 12-volt VPP.

**XTAL1**

Input to the inverting oscillator amplifier and input to the internal clock operating circuit.

**XTAL2**

Output from the inverting oscillator amplifier.

**Oscillator Characteristics**

XTAL1 and XTAL2 are the input and output, respectively, of an inverting amplifier which can be configured for use as an on-chip oscillator, as shown in Figure 1. Either a quartz crystal or ceramic resonator may be used. To drive the device from an external clock source, XTAL2 should be left unconnected while XTAL1 is driven as shown in Figure. There are no requirements on the duty cycle of the external clock signal, since the input to the internal clocking circuitry is through a divide-by-two flip-flop, but minimum and maximum voltage high and low time specifications must be observed.

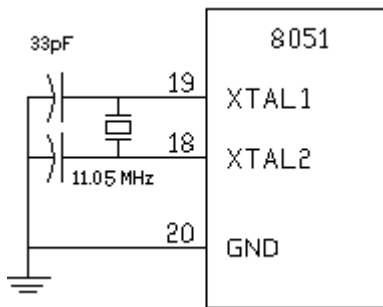

**Crystal Oscillator**

**Reset Circuit**

RESET is an active High input. When RESET is set to High, 8051 goes back to the power on state. The 8051 is reset by holding the RST high for at least two machine cycles and then returning it low.

**Power-On Reset**

- Initially charging of capacitor makes RST High
- When capacitor charges fully it blocks DC.

**Manual reset**

Closing the switch momentarily will make RST High. After a reset, the program counter is loaded with 0000H but the content of on-chip RAM is not affected

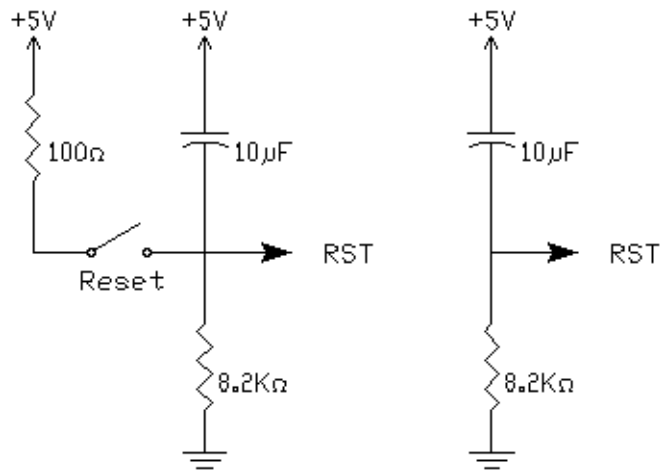

**Manual reset**

**Power-on reset**

**General Specifications of Micro-Controller-8051**

RAM	128 BYTES
ROM	4K
TIMERS	TIMER-0 & TIMER-1
INTERRUPTS	6-INTERRUPTS 2 INTERRUPTS – EXTERNAL 2 INTERRUPTS –TIMER 1 INTERRUPT – RESET 1 INTERRUPT – SERIAL PORT

**Pin diagram for 7805**



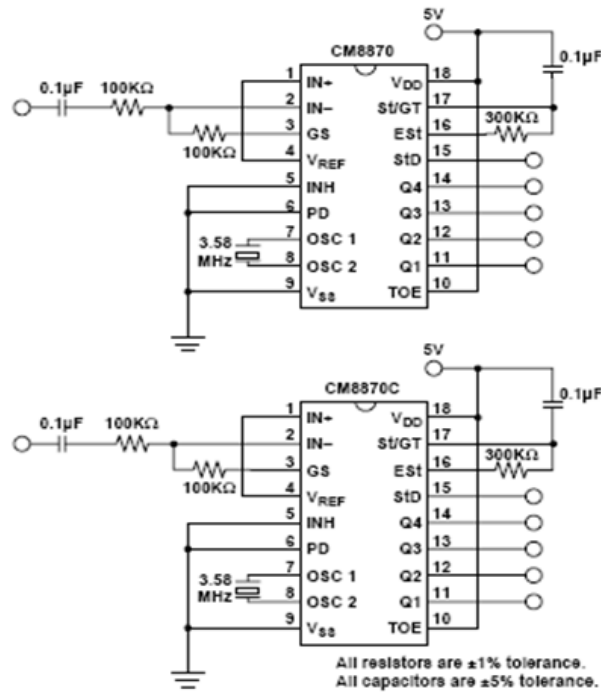

Figure 1. Single ended input configuration

### Pin Functions

Pin	Name	Description
1	IN+	Non-inverting input
2	IN-	Inverting input
3	GS	Gain select. Gives access to output of front-end amplifier for connection of feedback resistor.
4	V <sub>REF</sub>	Reference voltage output (nominally VDD/2). May be used to bias the inputs at mid-rail.
5	INH*	Inhibits detection of tones representing keys A, B, C, and D.
6	PD*	Power down. Logic high powers down the device and inhibits the oscillator. Internal pulldown.
7	OSC1	Clock input
8	OSC2	Clock output
9	VSS	Negative power supply (normally connected to 0 V).
10	OE	Tri-stable output enable (input). Logic high enables the outputs Q1 - Q4. Internal pullup.
11-14	Q1, Q2, Q3, Q4	Tri-stable data outputs. When enabled by OE, provides the code corresponding to the last valid tone pair received (see Tone Decoding table on page 5).
15	StD	Delayed steering output. Presents a logic high when a received tone pair has been registered and the output latch is updated. Returns to logic low when the voltage on St/GT falls below VTSt.
16	Est	Early steering output. Presents a logic high immediately when the digital algorithm detects a recognizable tone pair (signal condition). Any momentary loss of signal condition will cause Est to return to a logic low.
17	St/GT	Steering input/guard time output (bidirectional). A voltage greater than VTSt detected at St causes the device to register the detected tone pair and update the output latch. A voltage less than VTSt: frees the device to accept a new tone pair. The GT output acts to reset the external steering time constant, and its state is a function of Est and the voltage on St. (See Common Crystal Connection on page 5).
18	V <sub>DD</sub>	Positive power supply. (Normally connected to +5V.)

- 1. Unregulated voltage in
- 2. Ground
- 3. Regulated voltage out

#### **POSITIVE VOLTAGE REGULATORS**

- OUTPUT CURRENT UP TO 1.5 A
- OUTPUT VOLTAGES OF 5; 5.2; 6; 8; 8.5; 9; 12; 15; 18; 24V
- THERMAL OVERLOAD PROTECTION
- SHORT CIRCUIT PROTECTION
- OUTPUT TRANSITION SOA PROTECTION

#### **DTMF**

#### **IC- LM8870**

#### **Features**

- Low Power Consumption
- Adjustable Acquisition and Release Times
- Central Office Quality and Performance
- Power-down and Inhibit Modes (-02 only)
- Inexpensive 3.58 MHz Time Base
- Single 5 Volt Power Supply
- Dial Tone Suppression

#### **Applications**

- Telephone switch equipment
- Remote data entry
- Paging systems
- Personal computers
- Credit card systems

#### **DTMF Clock Circuit**

The internal clock circuit is completed with the addition of a standard 3.579545 MHz television color burst crystal. The crystal can be connected to a single LM-8870 as shown in the Single - Ended Input Configuration on page 3, or to a series of LM-8870s. As illustrated in the Common Crystal Connection below, a single crystal can be used to connect a series of LM-8870s by coupling the oscillator output of each LM-8870 through a 30 pF capacitor to the oscillator input of the next LM-8870.

#### **CONCLUSION :**

To operate industrial automation using GSM communication through 3G technology. To operate relay in microcontroller through DTMF tone. To generate DTMF signal through mobile key pad.

#### **REFERENCES**

1. Wikipedia - The free encyclopedia
2. <http://www.instructables.com/>
3. Schenker, L (1960), "Pushbutton Calling with a Two-Group Voice-Frequency Code", The Bell system technical journal 39 (1): 235–255, ISSN 0005-8580
4. "DTMF Tester", 'Electronics For You' Magazine, Edition (June 2003)
5. <http://www.alldatasheet.com>
6. <http://www.datasheet4u.com>
7. <http://www.datasheetcatalog.com>

Source of support: Nil; Conflict of interest: None declared